

Baureihe 35

Anschlußflansch und Kompensator druckseitig

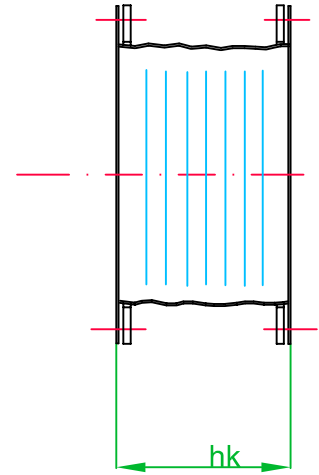

a	b	c	d	e*f	g*h	□ k	Schraubenanzahl	Gewinde	hk
166	106	17	9,0	2*100	2*70	30 x 6	8	M 8	100
186	118	17	9,0	2*110	2*76	30 x 6	8	M 8	100
206	131	17	9,0	2*120	2*82	30 x 6	8	M 8	100
230	146	17	9,0	2*132	2*90	30 x 6	8	M 8	100
256	166	22	11,0	3*100	2*105	40 x 8	10	M 10	150
286	186	22	11,0	3*110	2*115	40 x 8	10	M 10	150
321	206	22	11,0	3*122	2*125	40 x 8	10	M 10	150
360	231	30	14,0	4*105	3*97	50 x 8	14	M 12	150
408	258	30	14,0	4*117	3*106	50 x 8	14	M 12	150
460	258	30	14,0	4*130	3*116	50 x 8	14	M 12	150
510	324	30	14,0	5*114	3*128	50 x 8	16	M 12	150
570	364	30	14,0	5*126	4*106	50 x 8	18	M 12	200

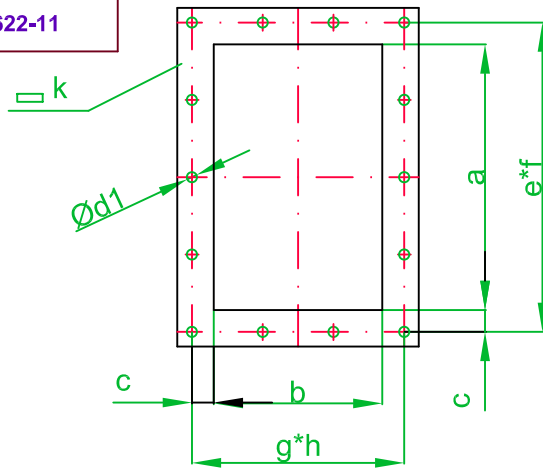
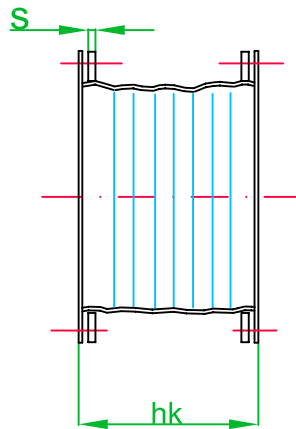
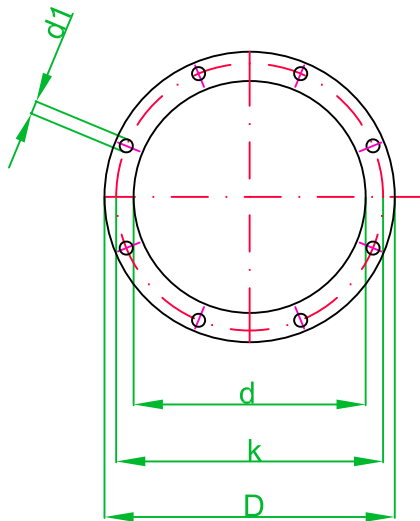

Baureihe 35

Anschlußflansch und Kompensator saugseitig

Nennweite Ø	Ød	ØD	Øk	Ød1	b x s	Schraubenanzahl	Gewinde	hk
140	145	205	179	9,0	30 x 5	6	M 8	100
160	165	225	199	9,0	30 x 5	6	M 8	100
180	185	245	219	9,0	30 x 5	6	M 8	100
200	205	265	239	9,0	30 x 5	8	M 8	100
225	230	310	274	11,0	40 x 8	8	M 10	150
250	255	335	299	11,0	40 x 8	8	M 10	150
280	285	365	329	11,0	40 x 8	8	M 10	150
315	320	420	380	14,0	50 x 8	12	M 12	150
355	360	460	420	14,0	50 x 8	12	M 12	150
400	405	505	465	14,0	50 x 8	12	M 12	150
450	455	555	515	14,0	50 x 8	12	M 12	150
500	505	605	565	14,0	50 x 8	16	M 12	200